



Adjustable wheel axle

Due to the adjustable wheel axle the lift's transport height can simply and easily be reduced to under 1.9 metres. This makes it possible to move the lift through normal double doors.



1. Self-drive operation from the basket. The operating panel is automatically in the basket when the boom is down in transport position, thus enabling the operation of the outriggers and the self-drive from up there. Therefore, it is no longer necessary for the lift user to leave the basket in order to change or move working positions.

3. Proportional control. Uncomplicated operation of all functions from the control panel in the basket.



2. The Diesel engine can be mounted either with or without generator. The Diesel engine is started and stopped from the basket.

4. The functional design of the cover-boards for the batteries, the hydraulic as well as the electric control allows easy and rational service and maintenance.

The big DL-series from DENKA LIFT – for the professional lift user.

The DL-series is specially constructed for use by rental companies which desire reliable machine safety, easy service as well as high working height and outreach.

The compact design makes it possible to place and work this lift even in areas where lifts of other brands would fail.

Thanks to the built-in manoeuvre function (self-drive) which is operable from the basket the lift can easily be moved over short distances by only one single person and without use of other helping aids.

Working heights are from 25 to 30 metres.

Automatic restriction of the load moment ensures optimum reach to suit the load in the basket.

In order to give the lift as much flexibility as possible it is as standard equipped with 8 pcs. 6V batteries. This large battery capacity prolongs the operating time and makes the lift especially suitable for job tasks with often changing working positions.

A diesel or benzin generator which can provide lift operation totally independent from the use of batteries can be delivered as extra accessory.

All DENKA LIFTs meet the most stringent safety standards.

The electrical and hydraulic systems have double safety devices and the cylindres have hose break valves.

All lift movements have a pressure control / valve safety system.

Technical data

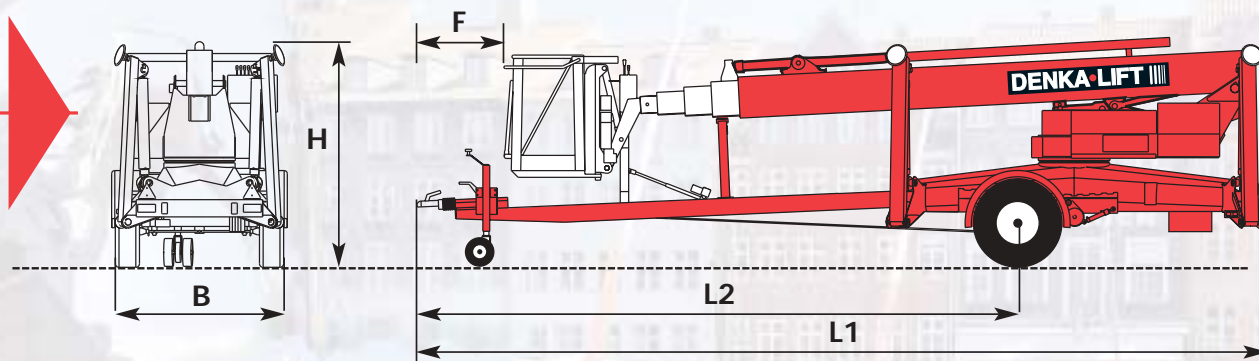

Max. working height

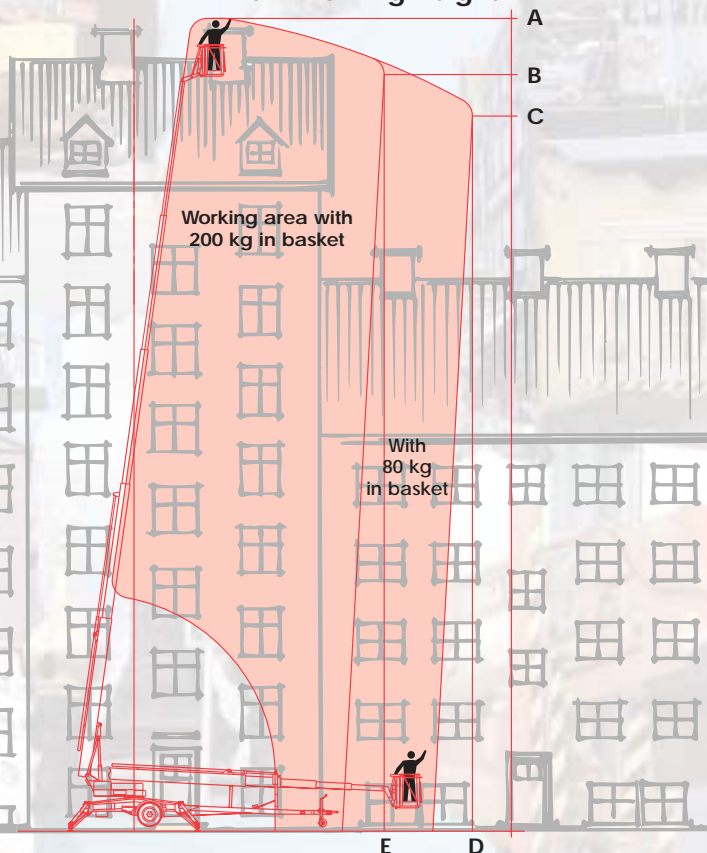

Outrigger cross section

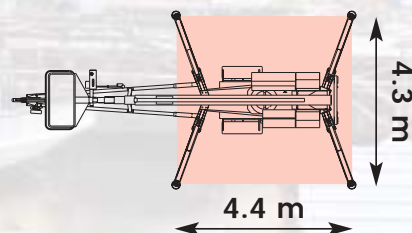

	Standard model DL25	DL30
Capacity		
Max. working height A	25.0 m	30.0 m
Working height B	23.0 m	28.3 m
Working height C	21.4 m	27.3 m
Max. reach D	12.0 m	11.6 m
Reach E	9.0 m	8.6 m
Max. load in basket	200 kg	200 kg
Slew movement	cont. 360°	cont. 360°
Transport dimension		
Length L1	8080 mm	8900 mm
Length L2	5640 mm	6380 mm
Height H	2140 mm	2140 mm
Width B	1720 mm	1720 mm
Distance F	850 mm	900 mm
Net weight standard	3200 kg	3500 kg

STANDARD EQUIPMENT:

- Rotating alu basket 1200 mm
- Battery operation
- Proportional control
- Hydraulic outriggers
- HFI relay 30 mmA
- Hour counter
- Charging key
- Hydraulic wheel drive from basket

EXTRA ACCESSORIES:

- Rotating fibreglass basket 1200 mm*
- Outlets for Water/air in the basket*
- Yellow rotating light
- Height limiting system 2 steps
- D.engine 5,2 KW w. charging generator 230V / 2,2 Kw (SP)*
- Special colours
- Yellow flashing light on outriggers
- High capacity battery*
- Height adjusting wheel axle*
- Biological degradable hydraulic oil
- Adjustable Basket from ground level

*increase in weight